

KOEH II

BIU/130

A	B	C	D	A	B	C	D		
1	S136 0052	406	194	4/4	13	S136 447	507	68	2/4
2	S136 555	619	409	4/4	14	S136 449	413	60	1/4
3	S136 181	753	600	2/4	15	S136 448	411	50	1/4
4	S136 180	753	600	2/4	16	S136 5509	500	120	2/4
5	S136 179	753	600	2/4	17	S136 5510	500	120	2/4
6	S136 1122	669	583	1/4	18	S136 5520	355	120	1/4
7	S136 1123	669	583	1/4	19	S136 943	499	370	2/4
8	S136 451	695	400	1/4	20	S136 5570	541	65	3/4
9	S136 5568	753	507	2/4	21	S136 550	753	65	3/4
10	S136 226	1300	700	1/4	22	S136 551	753	65	3/4
11	S136 342	670	400	1/4	23	S136 556	753	65	3/4
12	S136 341	507	583	2/4	24	S136 557	753	65	3/4

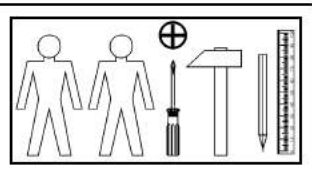
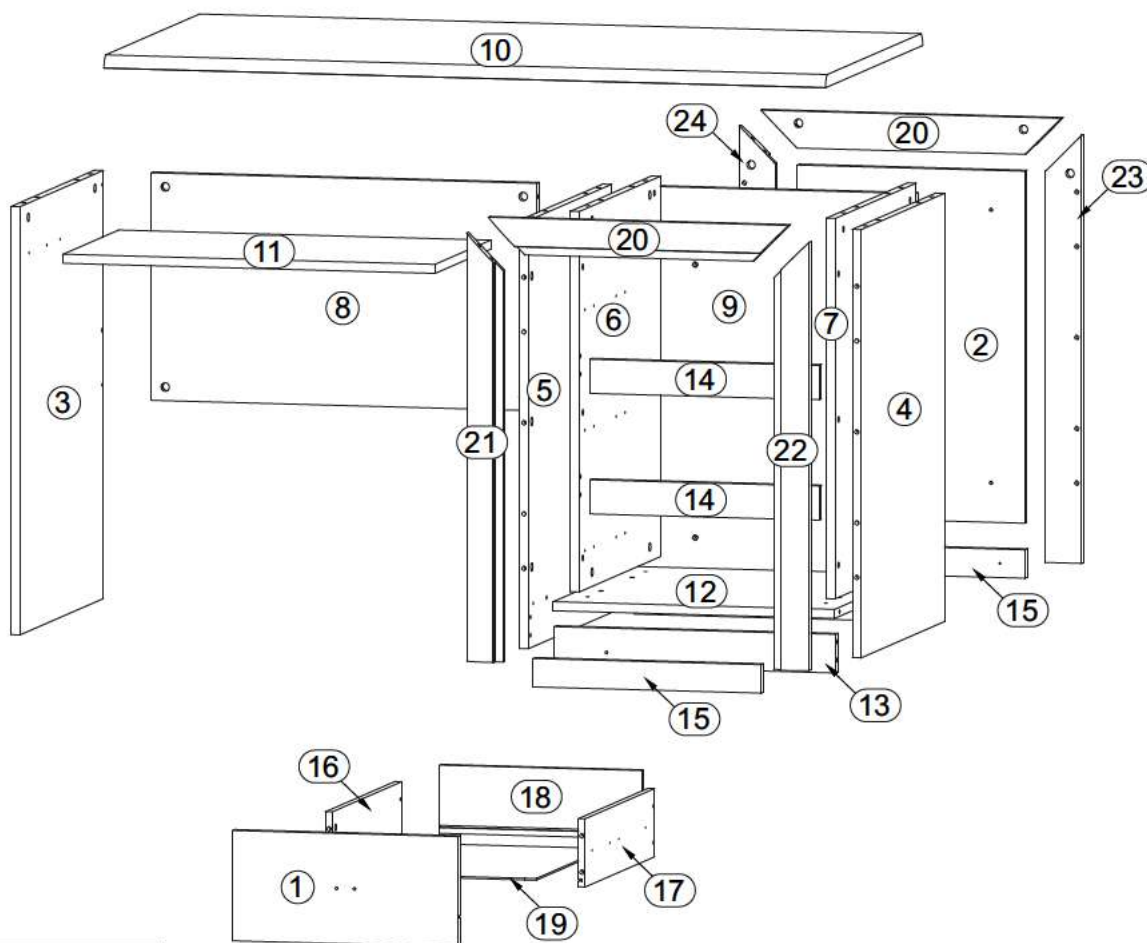
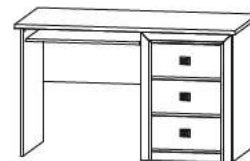

3x c317	30x φ6x13 mm e3	4x φ7x28 mm e22	12x φ5x50 mm e32	56x φ8x30 mm f1	6x M4x22 mm j30	6x k1	4x φ3,5x13 mm p27	4x φ4x28 mm p94
24x φ3,5x12 mm p140	48x φ15x12mm #16 r1	4x r10	40x 20/9 r16	18x φ16 s2	1x 350 mm w45 ^{CL}	1x 350 mm w45 ^{CR}	1x 350 mm w45 ^{DL}	1x 350 mm w45 ^{DR}
6x 500 mm w203 ¹	6x 500 mm w203 ²	1x Клей y1	1x z1					

1

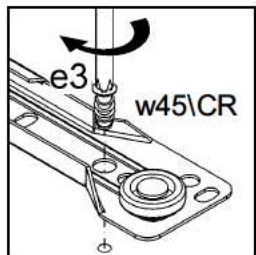
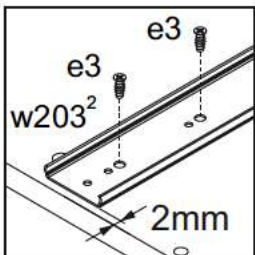
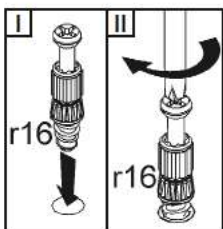
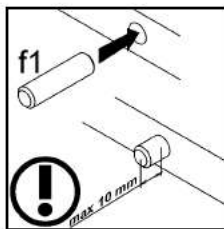
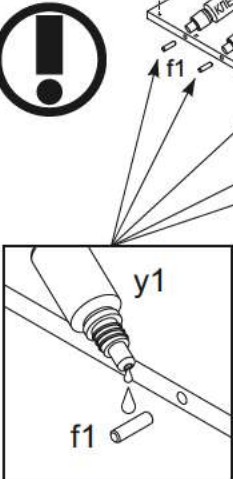
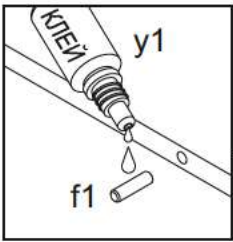
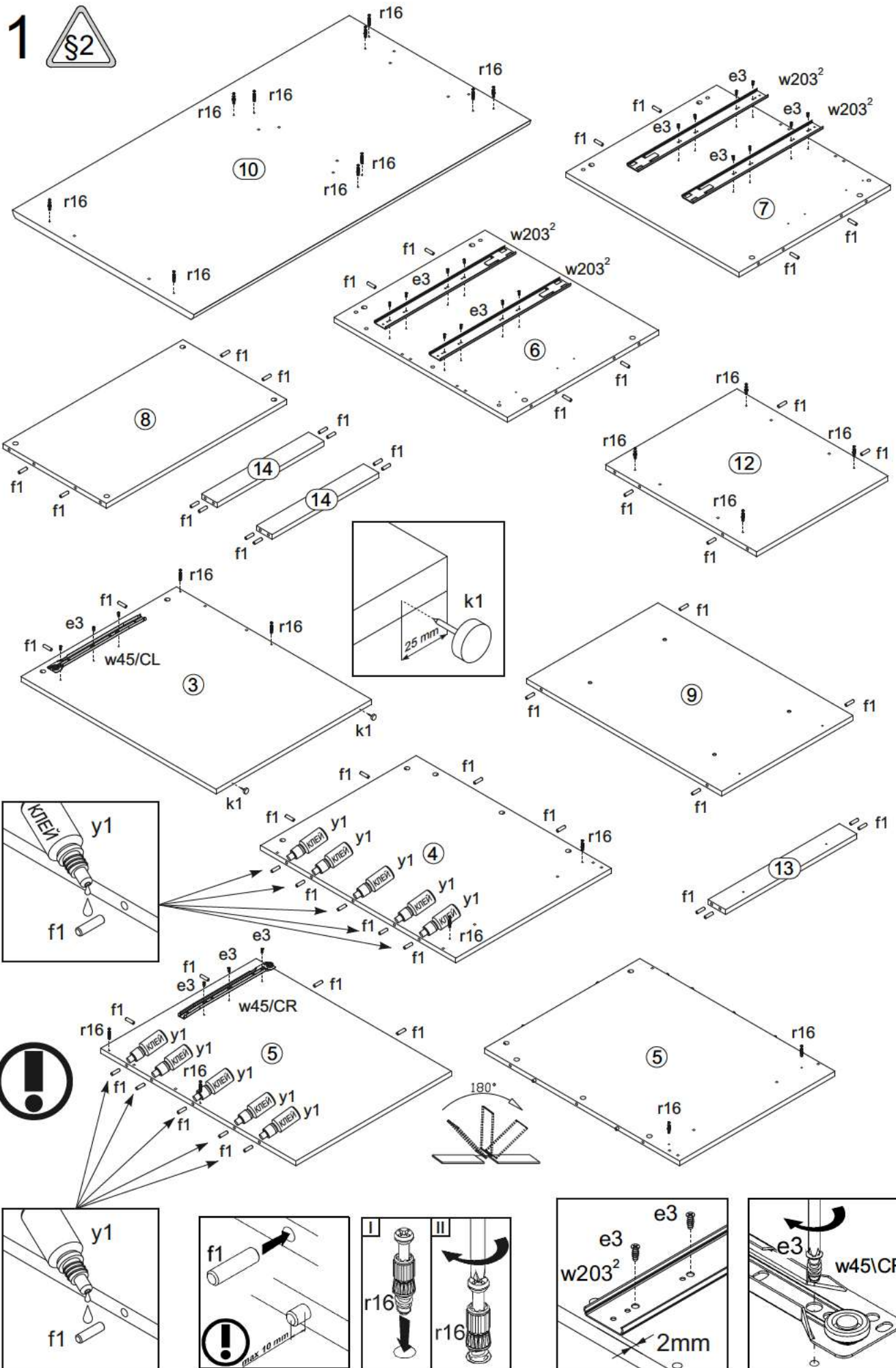

2

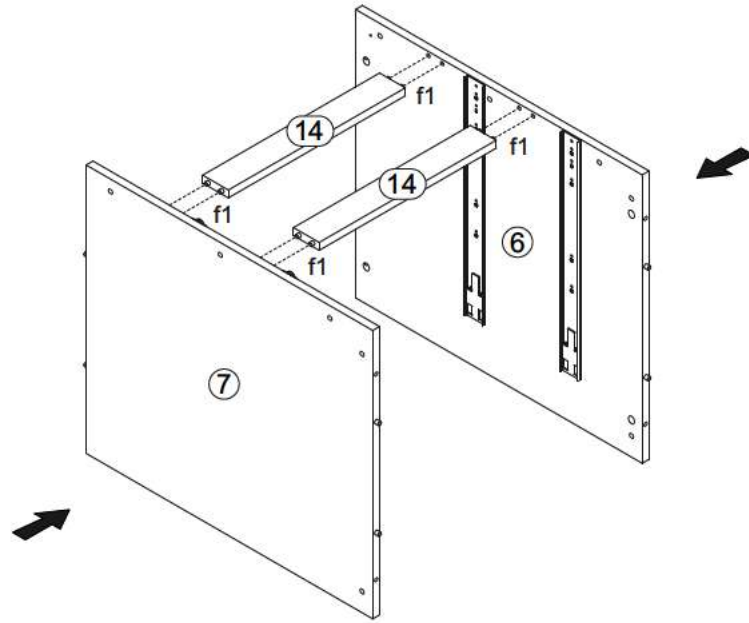

3

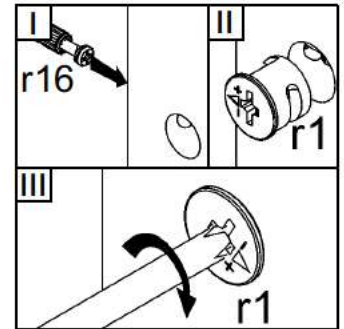
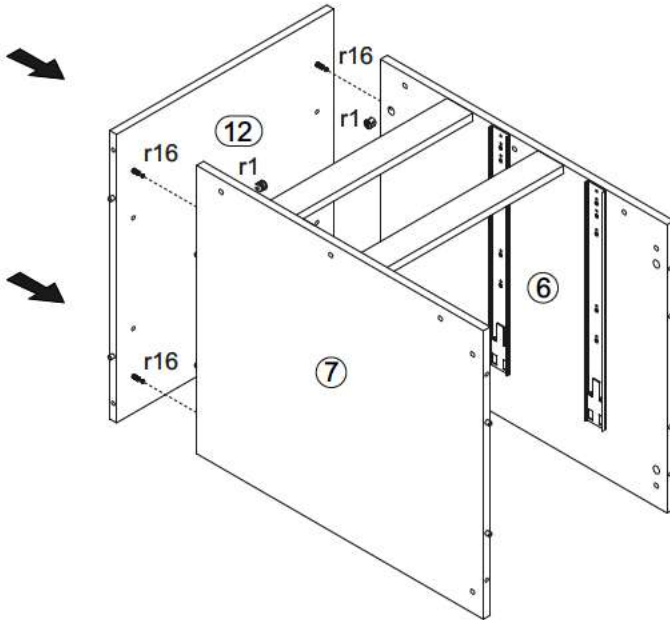

4

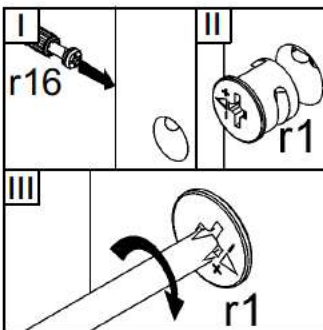
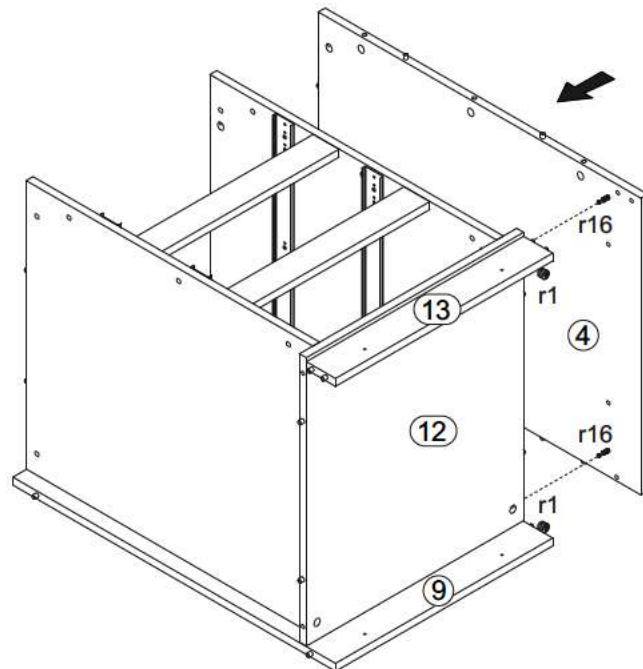

5

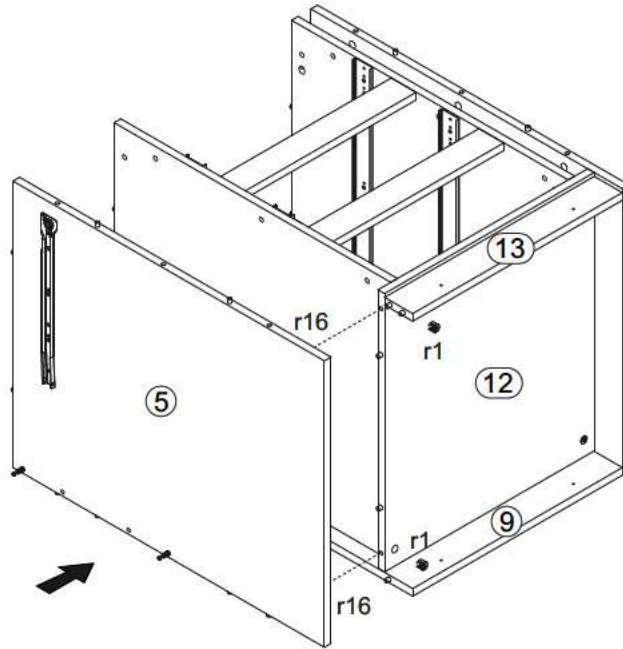
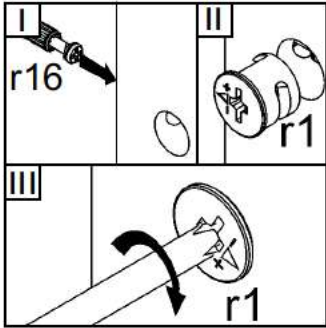

6

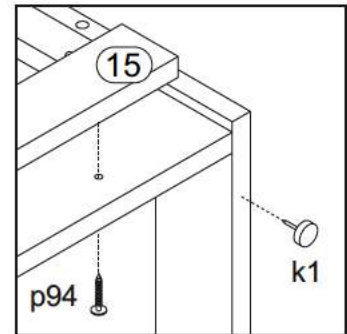
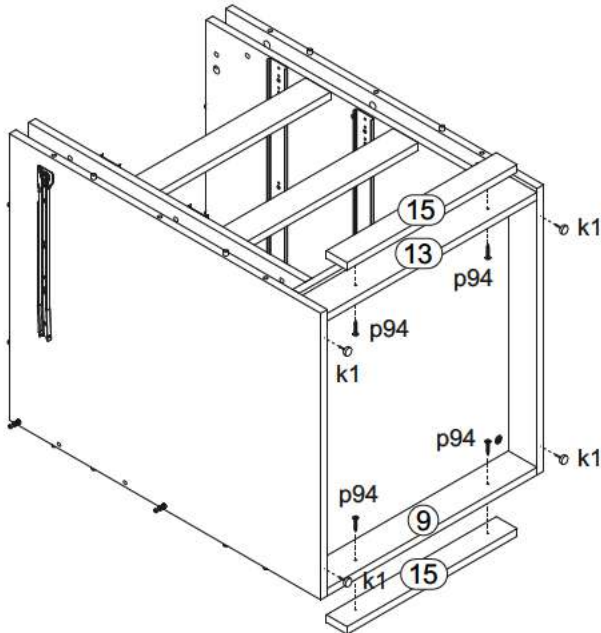

7

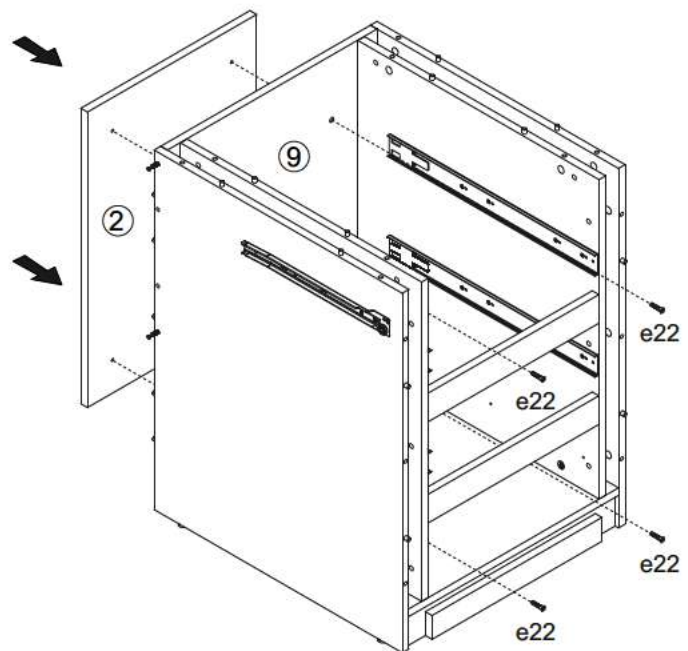
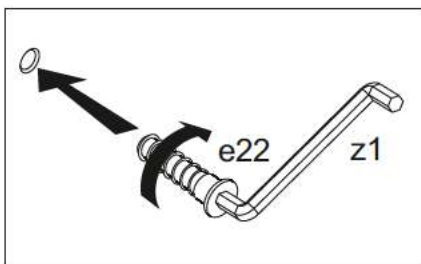

8

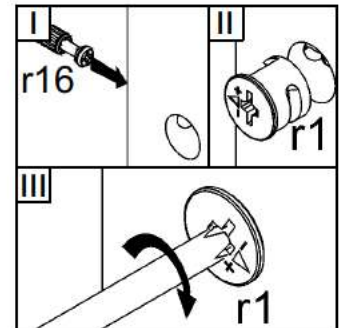
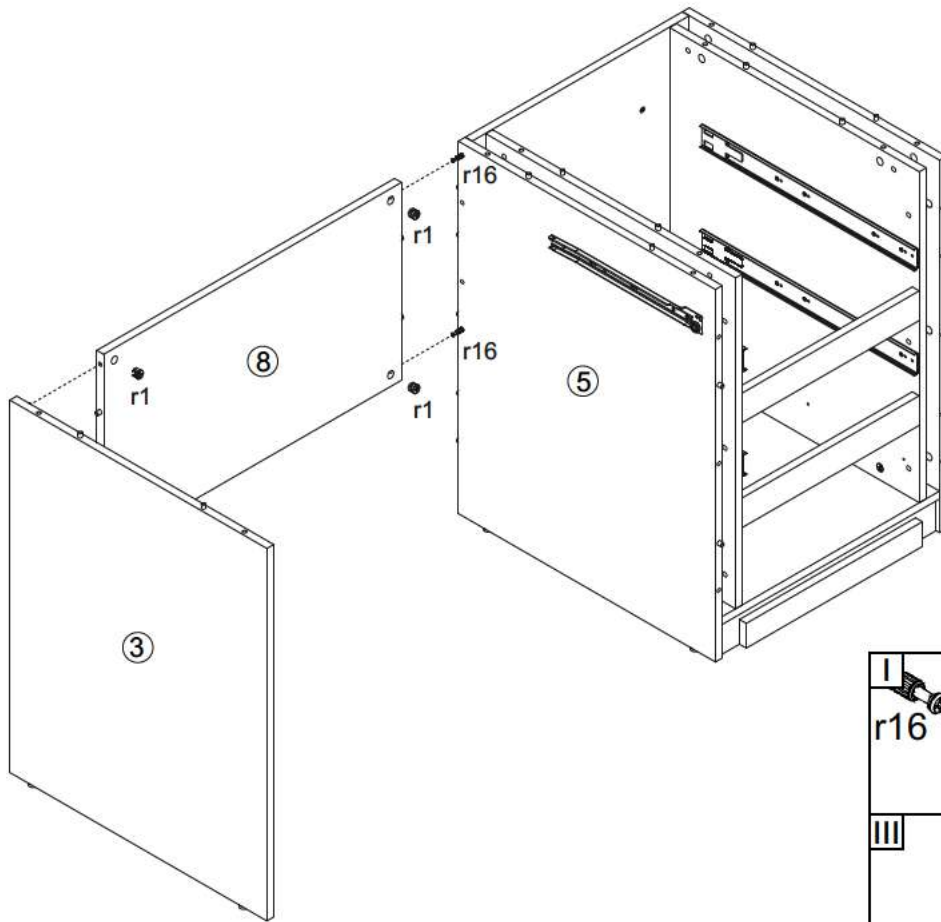

9

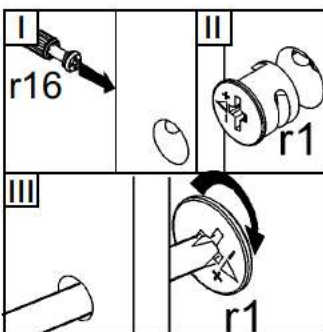
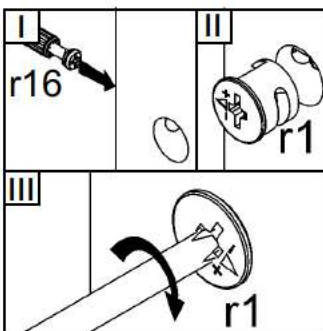
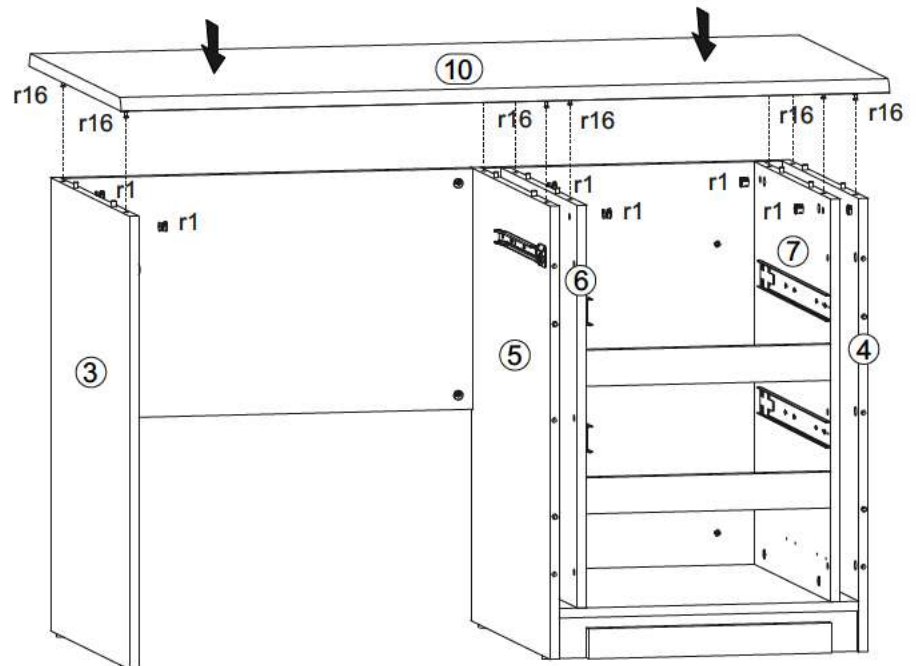

10

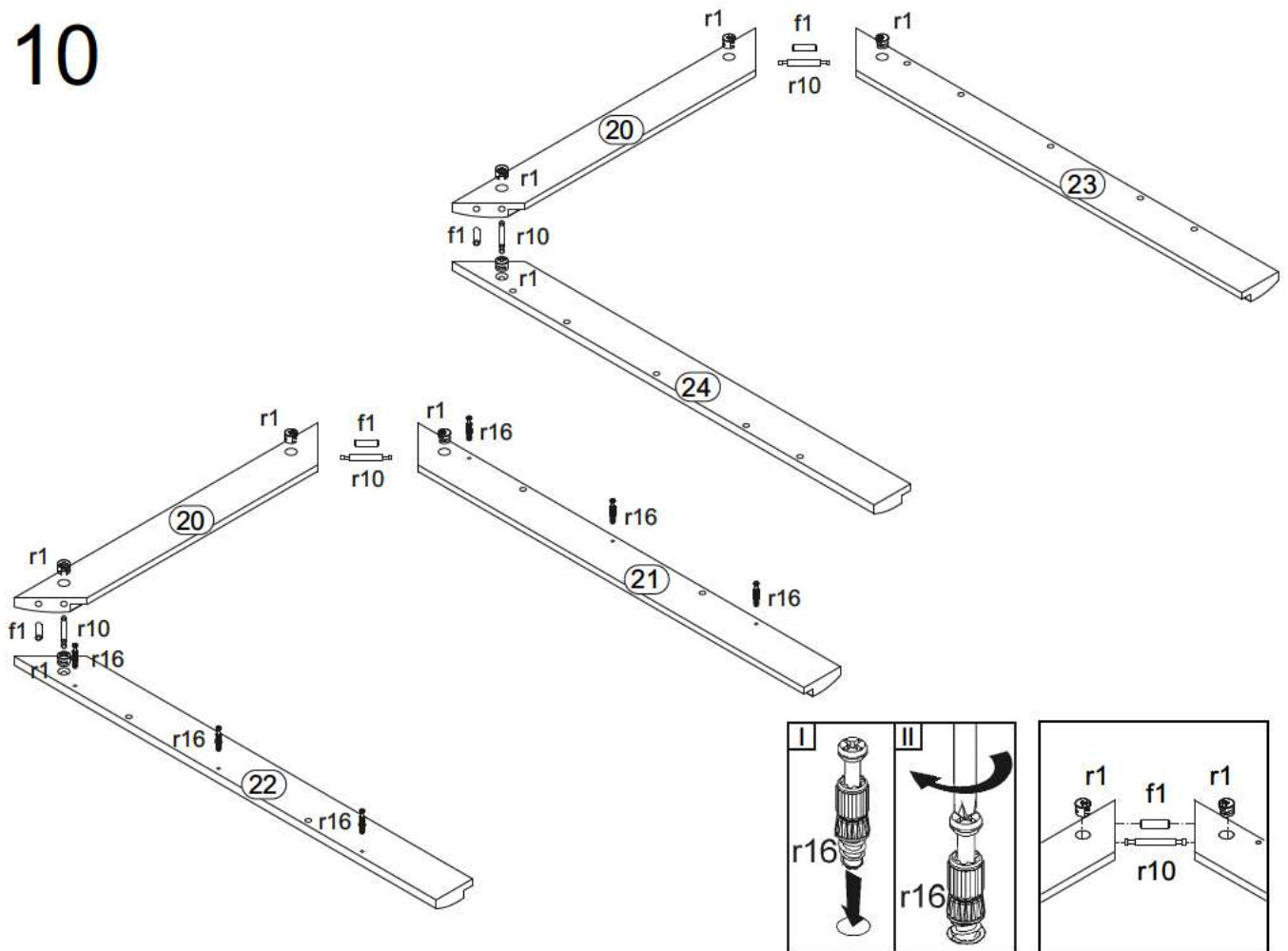

11

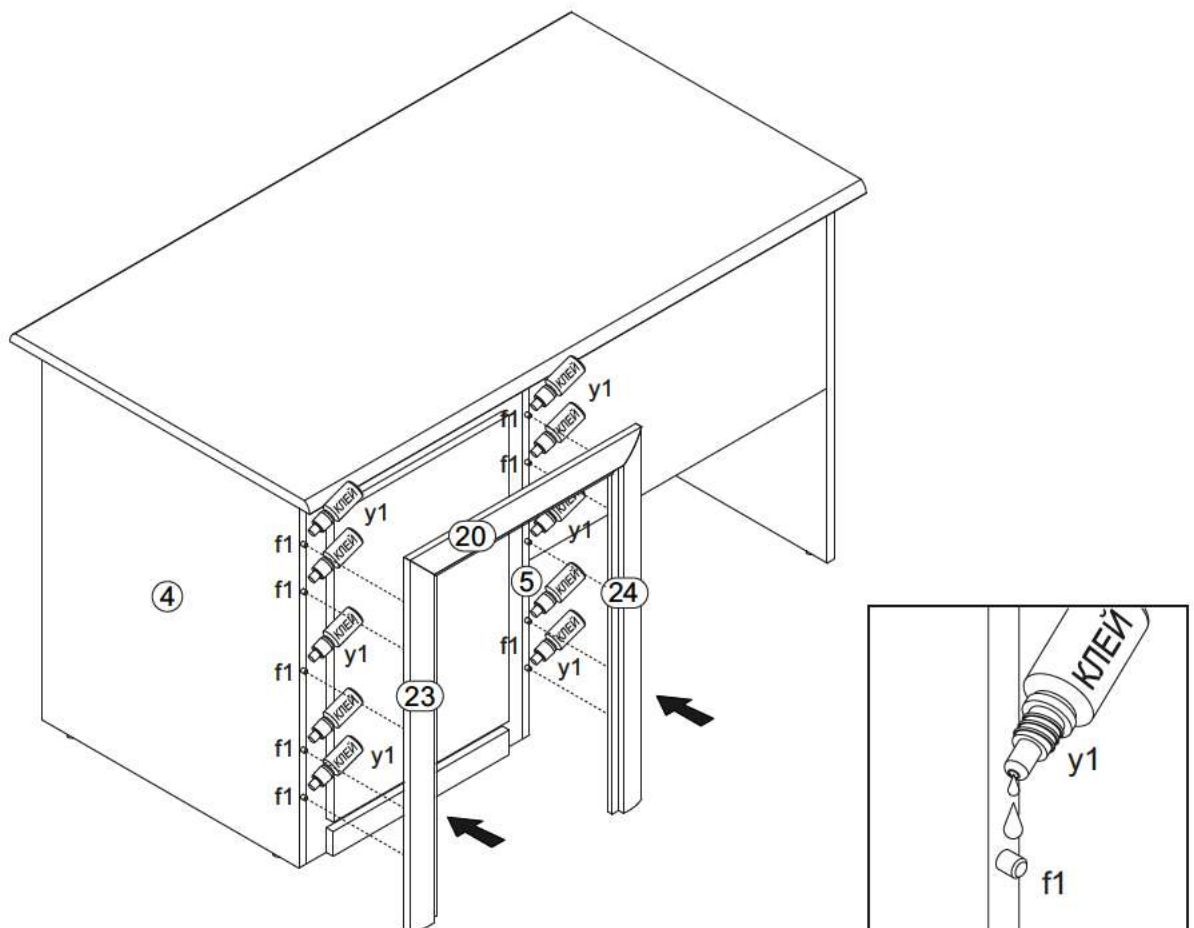

12

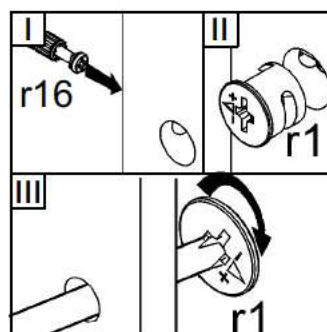
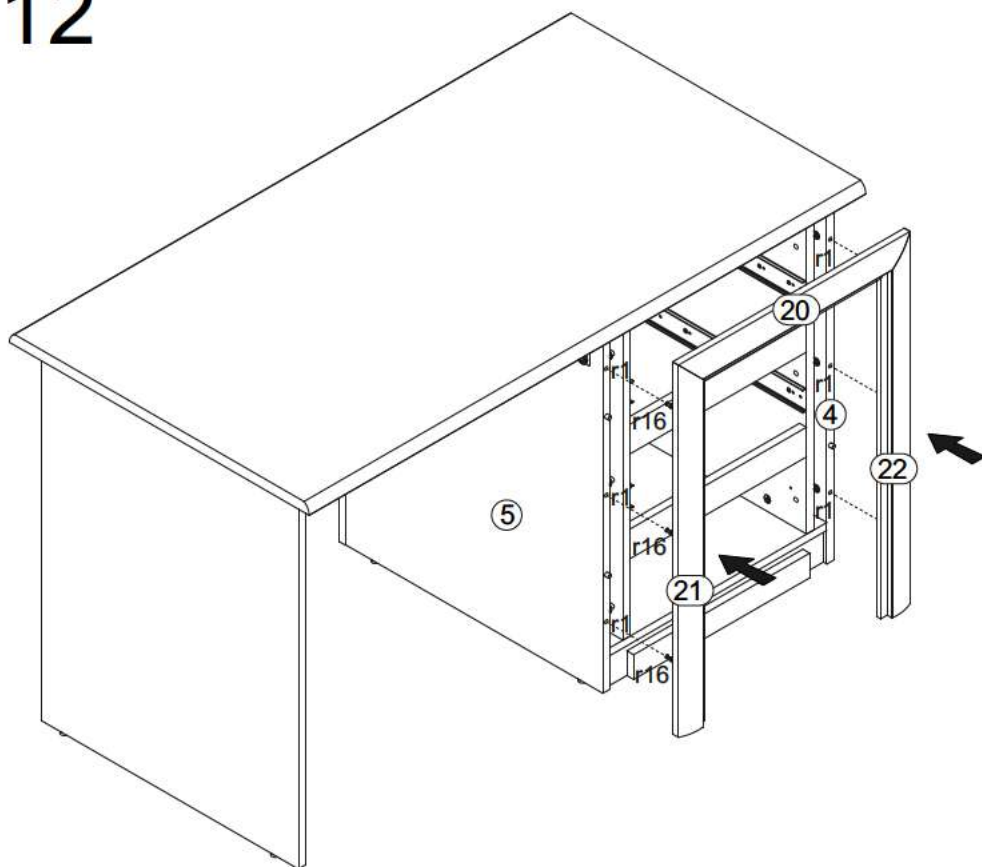

13

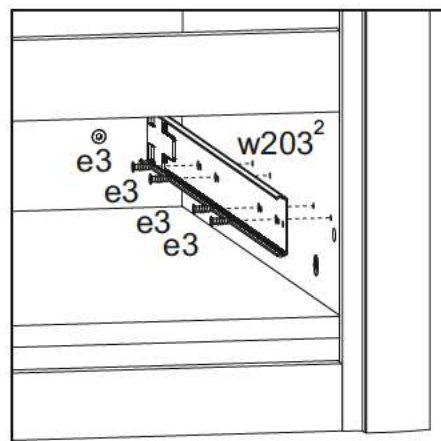
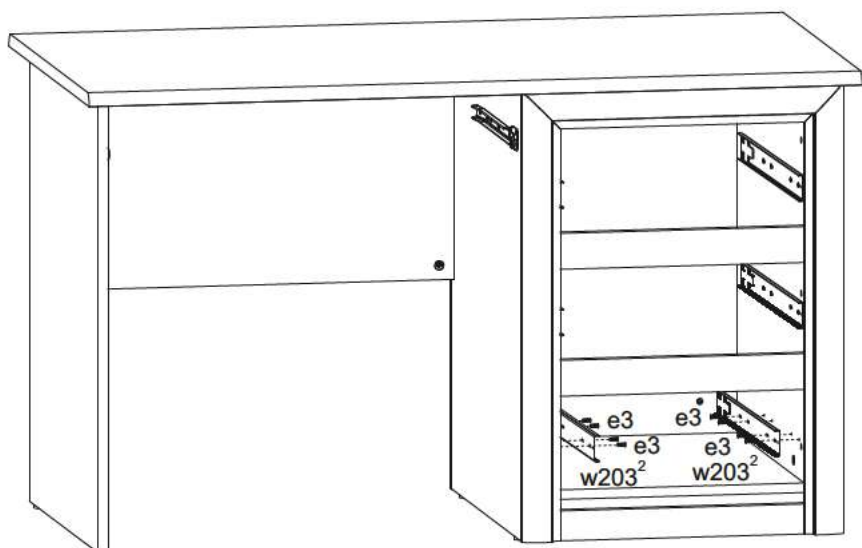

14

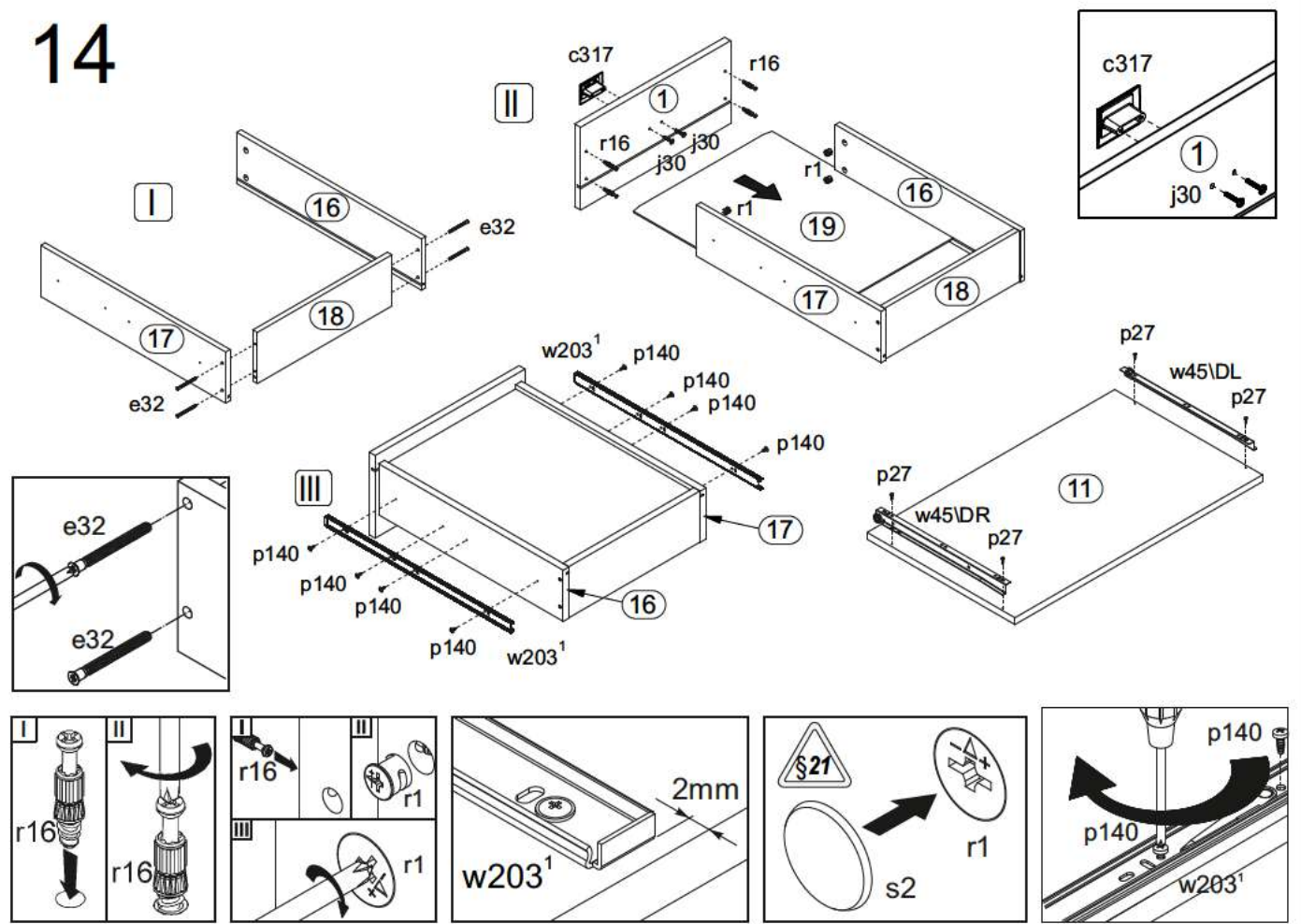

15

